

W & WH

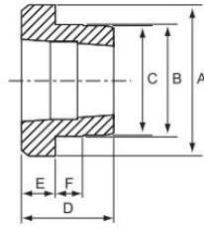

WG & WHG & WMG

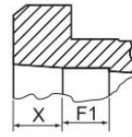

Welding relief



## Type W

Hub Size	Bush No.	A	B	C	D	E	F	F1	X
W12	1215	73.03	63.50	62.71	38.10	15.88	9.53	-	-
W16	1615	82.55	73.30	72.24	38.10	15.88	9.53	-	-
W25	2517	127.00	111.13	110.34	44.45	19.05	12.70	-	-
WG30	3030	149.86	133.35	132.56	76.20	25.40	19.05	23	23
WG35	3535	184.15	158.75	157.96	88.90	31.75	25.40	30	30
WG40	4040	225.43	196.85	196.06	101.60	31.75	31.75	34	34
WG45	4545	254.00	222.25	221.46	114.30	38.10	38.10	38	38
WG50	5050	276.00	241.00	240.25	127.00	38.10	38.10	42	42
WG60	6050	375.00	343.00	342.00	127.00	38.10	38.10	42	42
WG70	7060	425.00	375.00	374.00	153.00	51.00	51.00	51	51
WG80	8065	445.00	394.00	393.00	165.00	51.00	51.00	55	55
WG100	10085	559.00	495.00	494.00	216.00	51.00	51.00	72	72

## Type WH

Hub Size	Bush No.	A	B	C	D	E	F	F1	X
WH12	1210	70	65	64.5	25	9	10	-	-
WH16-1	1610	80	75	74.5	25	9	10	-	-
WH20	2012	95	90	89.5	32	12	12	-	-
WH25	2517	115	110	109.5	44	19	15	-	-
WHG30-2	3020	145	140	139.5	50	20	15	17	17
WHG35	3525	190	180	179.5	65	25	25	22	22
WHG40-1	4030	200	190	189.0	76	32	30	25	25
WHG40-2	4040	200	190	189.5	101	32	30	34	34
WHG45-1	4535	210	200	199.5	89	40	30	30	30
WHG45-2	4545	210	200	199.5	114	40	30	38	38
WHG50-1	5040	230	220	219.5	102	40	35	34	34
WHG50-2	5050	230	220	219.5	127	40	35	42	42

## Type WM

Hub Size	Bush No.	A	B	C	D	E	F	F1	X
WMG12	1210	70	60	58	26	9	10	9	9
WMG16-1	1610	83	70	68	26	9	10	9	9
WMG16-2	1615	83	70	68	38	16	11	13	13
WMG20	2012	95	90	88	32	12	12	11	11
WMG25	2517	127	110	108	44	19	13	15	15
WMG30-2	3020	152	130	125	50	20	15	17	17
WMG30-3	3030	152	130	125	76	25	19	25	25
WMG35	3535	184	155	151	89	32	25	30	30
WMG40	4040	225	195	187	102	32	32	34	34
WMG45	4545	254	220	213	114	38	38	38	38
WMG50	5050	276	242	228	127	38	38	42	42

"G" notation represents welding relief.

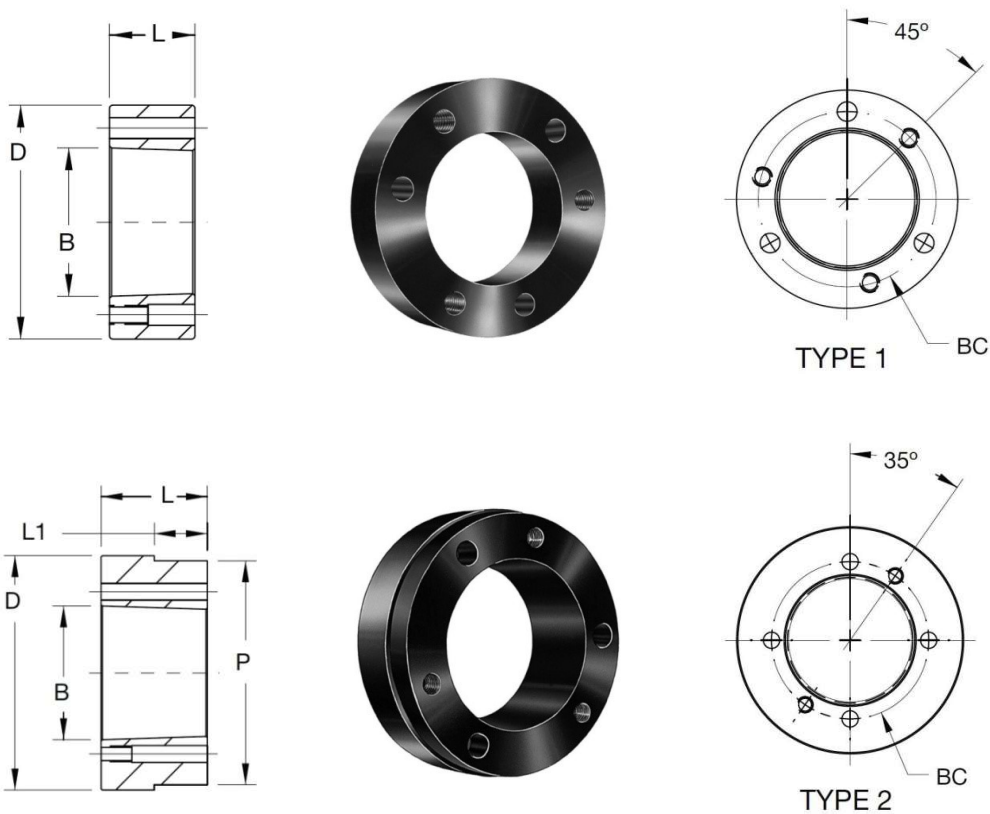

## Type QD bushed Hubs

Hubs	D	L	B	BC	TYPE
JA-A	2.25	.9/16	1.37	1.21/32	1
SH-A	3.00	.13/16	1.87	2.1/4	1
SDS-A	3.50	.3/4	2.18	2.11/16	1
SK-A	4.375	1. 1/4	2.81	3.5/16	1
SF-A	5.00	1. 1/4	3.12	3.7/8	1
E-A	6.25	1. 5/8	3.83	5	1
F-A	7.00	2. 1/2	4.44	5.5/8	1
J-A	7.75	3. 3/16	5.14	6.1/4	1
M-A	9.50	5. 3/16	6.49	7.7/8	2
N-A	10.50	6. 1/4	6.99	8.1/2	2
P-A	13.00	7. 1/4	8.24	10	2
W-A	15.50	9	10.43	12.3/4	2

Hubs Material: Steel C45  
 Surface treatment: Oil.

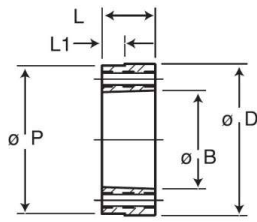

ALL TAPERS 3/4" PER FT.  
ON DIAMETER

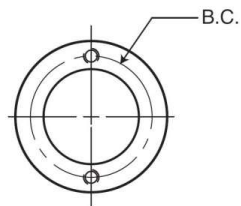

"H" HUBS

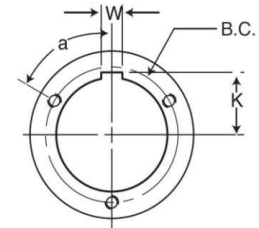
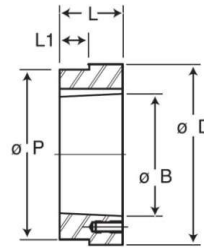

"P", "Q", "R", "S", "Y" "U" HUBS

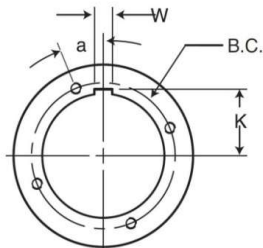
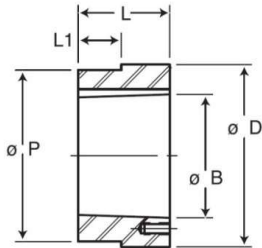

"W" HUBS

## Type STL bushed Hubs

Hubs	D	P	L	L1	BC
HH1	2.50	2.375	0.88	0.174	2.000
HCH1	2.50	2.375	0.88	0.625	2.000
HP1	3.00	2.875	1.31	0.292	2.438
HCP1	3.00	2.875	1.310	1.000	2.438
HP2	3.00	2.875	2.31	1.100	2.438
HQ1	4.50	4.375	1.75	0.709	3.375
HCQ1	4.50	4.375	1.75	1.250	3.375
HQ2	4.50	4.375	2.75	1.606	3.375
HR1	5.75	5.625	2.00	0.709	4.625
HR2	5.75	5.625	4.00	1.606	4.625
HS1	6.75	6.500	3.31	0.946	5.375
HS2	6.75	6.500	5.69	2.963	5.375
HU0	8.50	8.250	3.75	2.000	7.000
HU1	8.50	8.250	5.62	2.963	7.000
HU2	8.50	8.250	8.62	6.016	7.000
HW1	12.50	12.250	6.38	2.963	10.000

Hubs Material: Steel C45

Surface treatment: Oil.